



INSTALLATION & SERVICE INSTRUCTION MANUAL FOR KATES FLOW RATE CONTROLLERS, MODELS A THRU C.

IMPORTANT

1. THE KATES FLOW RATE CONTROLLER IS DESIGNED TO ACCURATELY REGULATE FLOW RATES AND IS PRECISION BUILT WITH EXACTING TOLERANCES AND FINISHES. TO INSURE SATISFACTORY PERFORMANCE, THE REGULATED FLUID **MUST BE CLEAN** AND FREE OF DIRT OR SOLIDS.

THE INSTALLATION OF A 10 MICRON FILTER IS RECOMMENDED, JUST UPSTREAM FROM THE CONTROLLER.

2. EQUALLY IMPORTANT: WHEN DIS-ASSEMBLING, SERVICING, OR CLEANING THE CONTROLLER, THE INTERNAL PARTS **MUST BE HANDLED WITH CARE** TO PREVENT DAMAGING THE SURFACE FINISH IN ANY WAY.

3. OPERATION OF A KATES FLOW RATE CONTROLLER SUPPLIED BY A POSITIVE DISPLACEMENT PUMP, WILL BE SATISFACTORY **ONLY** IF A PRESSURE-RELIEVING VALVE IS CONNECTED BETWEEN THE PUMP AND THE CONTROLLER TO BYPASS EXCESS FLUID BACK TO THE FLUID SOURCE, OR TO THE INTAKE OF THE PUMP.

INSTALLATION

1. The Kates Flow Rate Controller is shipped fully assembled, ready for operation, with all parts in place. It is completely self-contained, requires no outside source of power, no straight piping runs, and is as simple to install as an ordinary angle valve.
2. Upstream and downstream shutoff valves and a bypass valve should be installed so that the controller may be opened for inspection and cleaning without requiring complete system shutdown. (See fig. 3)
3. Before installing the controller, be sure to flush out the piping system to remove any foreign material such as dirt, scale, chips, etc.
4. All controllers are constructed substantially, but pipe supports should be located so that the controller is not subject to mechanical load due to piping, or to the expansion or contraction of piping.
5. The controller should be installed at a point in the pipe where it will be completely filled with liquid under all conditions of operation. The preferred axis of the controller is vertical, with the bonnet up. **INLET IS AT SIDE** and outlet connection is at bottom. On threaded connections, apply pipe thread compound sparingly to male threads only, so that surplus will not get inside the controller.

START UP PROCEDURE

Note: If the flow rate setting knob does not turn, loosen the dial lock screw. (See fig. 1)

1. The pointer on the stainless steel nameplate should be at front, readily visible to operator. If not, proceed as follows:
 - a) Loosen and remove the bonnet bolts.
 - b) Lift the bonnet straight up and turn until the pointer faces front.
 - c) Make sure the body O-ring is in good condition and is in place.
 - d) Lower the bonnet slowly, at the same time turning the flow rate setting knob until the key on the end of the adjuster shaft fits into the slots in the orifice sleeve, and the shoulder on the lower face of the bonnet fits into the body. When properly assembled, bonnet will seat squarely on the body all the way around. (See fig. 1)
 - e) Replace and tighten the bonnet bolts. (See fig. 4)
2. By hand, turn the flow rate setting knob in both directions until the stop pin inside the controller prevents further rotation. If it does not turn easily without sticking, or if it does not hit the stop pin in both directions, follow directions below "To Clean Controller".
CAUTION: Never use a wrench or attempt to force the knob to turn.
3. Turn the flow rate setting knob clockwise until it hits the internal stop pin. The lowest set point at right hand end of dial should now line up with the pointer. If not, loosen the dial clamp screws on the top of the knob, turn the dial until the lowest set point on the dial lines up with pointer and retighten the screws.
4. Turn the flow rate setting knob until the desired flow rate mark on the dial lines up with the pointer on the nameplate.
5. Place controller in service by opening upstream and downstream shutoff valves and closing the bypass valve around the controller. Controller will now regulate the flow rate at the set value. (See fig. 3)
NOTE: Avoid slamming the controller with pressure.
6. If there is air trapped in the top of the controller, this should be purged by the liquid after a short period.
7. When the flowing fluid temperature is above room temperature, especially with viscous fluids, there may be a "warming up" period until the controller reaches the same temperature as the fluid. During this warming up period, the controller may be somewhat sluggish in action. If desired, this warming up period may be eliminated by the use of a heating coil or jacket.
8. During the first few days of operation, gasketed joints should be observed and tightened if necessary.

SERVICE INSTRUCTIONS

The Kates Flow Rate Controller has only one moving element, and is designed so that there are no complex linkages, delicate bearings, or any failure-prone components. Therefore, occasional cleaning may be the only servicing the controller will require.

CAUTION: MAKE SURE THAT THE CONTROLLER IS RELIEVED OF PRESSURE BEFORE ATTEMPTING TO SERVICE OR CLEAN.

TO CLEAN CONTROLLER

CAUTION: in all cleaning operations, be very careful not to scratch, nick or mark any surfaces or edges.

1. The controller operates by downward flowing liquid and is self cleaning for most liquids. Downflow design also will allow drainage on shutdown of many systems if discharge shutoff valve is closed after inlet shutoff valve.
2. It is not necessary to remove the controller from the line to clean. If installation includes proper shutoff and bypass valves, operate these and take controller off stream or control. (See fig. 3)
3. Arrange a clean area where internal parts can be placed and kept free of dirt.
4. Remove bonnet bolts, lift bonnet assembly straight up, remove body O-ring, and place both in the clean area.
5. Lift out the orifice sleeve with piston assembly and place in the clean area.
6. Remove the orifice cylinder clamp screws, then lift out the orifice cylinder, and place in the clean area.
7. Remove the valve sleeve and spring and place in the clean area.
8. Valve tube is now exposed and can usually be cleaned in place. If removal is necessary, use a 7/8" deep socket wrench.
9. Thoroughly clean all parts that have been removed from the controller by immersing them in a suitable solvent. Clean and flush inside of flow controller body and the valve tube with the solvent, and drain. Because of the small size of the orifice slot and the closely fitted parts, it is VERY IMPORTANT that all parts and surfaces, especially the orifice slot and valve ports, be COMPLETELY CLEAN, and that any dirt, sediment, coating or gummy residue must be completely removed. Wipe all parts and surfaces dry with a clean, lint-free cloth.
10. If the valve tube was removed, replace insuring that it seats correctly, and is central in the controller body.
11. Install the spring insuring that it seats properly.
12. Replace the valve sleeve making sure that it slides freely up and down the valve tube with no sticking.
13. Replace orifice cylinder, insuring that it seats firmly in the body. The slot should face the inlet pipe.
14. Replace orifice sleeve, and make sure that it turns freely in both directions until it hits the vertical stop pin.
15. Install the piston with the push rod down. Operate piston several times to insure that piston assembly, spring, and valve sleeve all cooperate and that there is no binding.
16. Replace body O-ring, then lower the bonnet slowly, at the same time turning the flow rate setting knob until the key on the end of the adjuster shaft fits into the slots in the orifice sleeve, and the shoulder on the lower face of the bonnet fits into the body. When properly assembled, bonnet will seat squarely on the body all the way around. (See fig. 1) See that the pointer is in front where set point can be read. Replace and tighten the bonnet bolts. (See fig. 4)
17. Place controller in service as specified under steps 2-7, "START UP PROCEDURE".

TO REPLACE ADJUSTER SHAFT PACKING:

1. The only packing required is between the adjuster shaft and the bonnet. This consists of a PTFE thrust washer and an O-ring of standard size and of a material that is suitable for use with the liquid flowing through the controller. For high pressures, a thrust bearing is used. (See fig. 2)
2. To replace the thrust washer and O-ring, remove the bonnet, and then remove flow rate setting knob by removing knob clamp screw and lifting dial and knob assembly upwards. Adjuster shaft can now be removed by pulling it through the bonnet from the inside.
3. Remove the existing O-ring by prying it out of the groove in the shaft, using a blunt-ended hook. (With a PTFE O-ring, first immerse the adjuster shaft in warm water to slightly soften the O-ring).
CAUTION: Be careful not to scratch the groove or the shaft.
4. Remove the existing thrust washer, and replace with a new thrust washer. Run the washer down the shaft until it rests on the shoulder.
5. Slide a new O-ring down the adjuster shaft until it fits properly in the groove. (With a PTFE O-ring, first immerse it in warm water to soften it slightly.)
6. Carefully push the adjuster shaft through the bonnet from the inside until the thrust washer is held tightly between the shoulder on the shaft and the shoulder on the bonnet. Observe that there are flats at the top of the shaft and the bottom of the hole in the knob. Place knob on shaft with both sets of flats aligned so the shaft will key into the knob. Support shaft from below, then press or tap knob down on shaft. If flats on shaft do not fit into those in knob, turn knob slightly, then tap or press it down into place. Replace knob clamp screw to hold knob in place.
7. Replace the bonnet, and place the controller in service by following Steps 2-7 listed under the heading "START UP PROCEDURE".

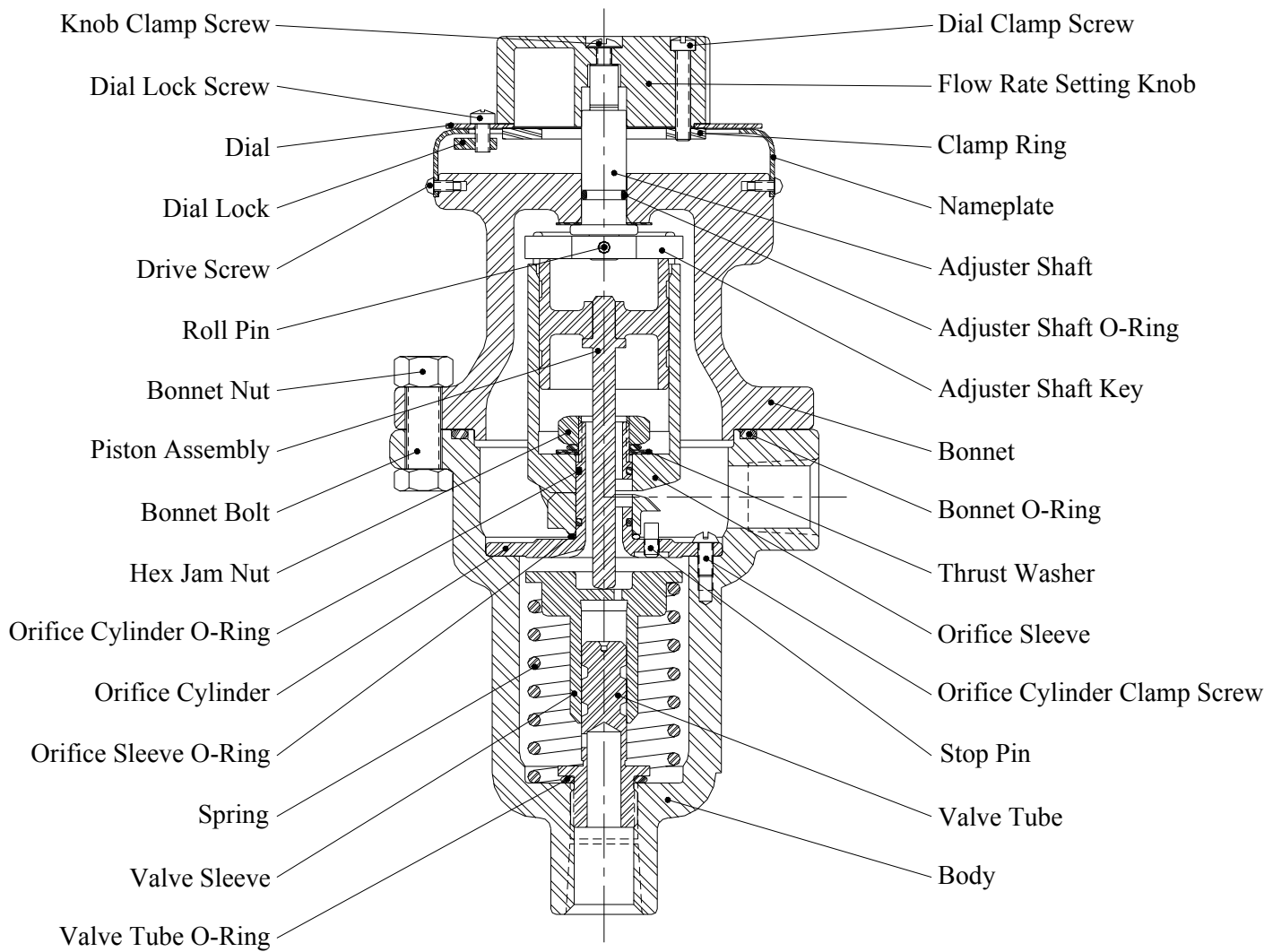

Figure 1

FOR 600# & HIGHER UNITS

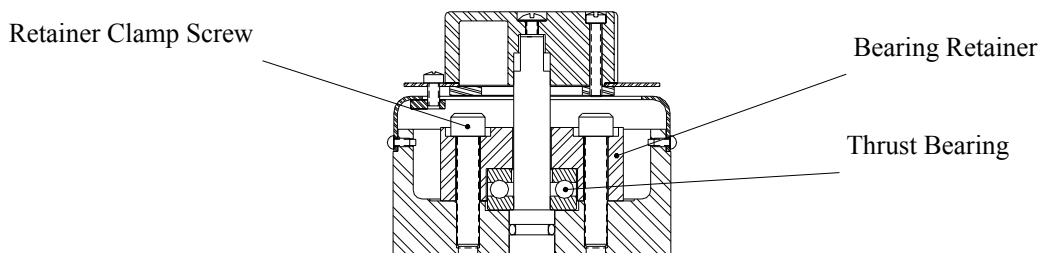

Figure 2

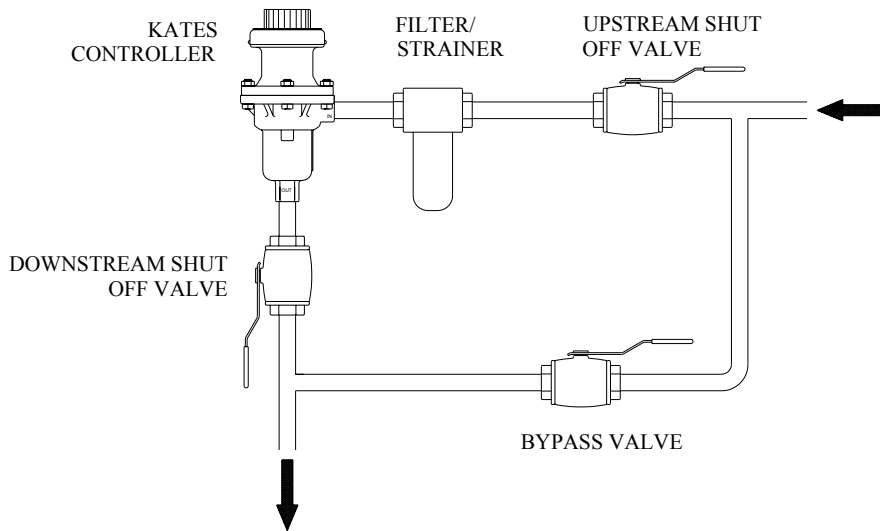

Figure 3

ANSI Pressure Class	Bolt Torque (ft.lb)
150/300#	10
600#	28
900/1500#	68

Figure 4

PRODUCT WARRANTY

The W.A. KATES COMPANY guarantees every piece of equipment manufactured by it to be inspected, tested, and free from defects in workmanship or material when shipped from its factory. No warranty of corrosion resistance of any parts or assembly is expressed or implied.

This guarantee is valid for one year from date of shipment from its plant. Within that time, the W.A. KATES COMPANY will replace free of charge any equipment returned, with shipping charges prepaid, found to have been defective at time of shipment.

This warranty does not apply to : (a) damage resulting from misuse or inadequate handling; (b) damage resulting from continued use after defect is apparent; (c) any other damage, loss or liability; or (d) any piece of equipment that is changed, modified or altered in any way after it leaves the factory.

The liability of the W.A. KATES COMPANY shall be limited to the replacement, f.o.b. our factory, of any equipment found to have been defective at time of shipment with duplicate or similar equipment of equal performance rating, but such liability shall in no event exceed the contract price for said equipment.

W. A. KATES CO. 1363 Anderson, Clawson, Michigan 48017

Tel (248) 435-8225 - Fax (248) 435-8255

E-mail: info@wakates.com

Internet: <http://www.wakates.com>