



INSTALLATION & SERVICE INSTRUCTIONS FOR KATES MODEL FM38, FM50 AND FM75 ADJUSTABLE FLOW RATE CONTROLLERS

IMPORTANT

THE KATES FLOW RATE CONTROLLER IS DESIGNED TO ACCURATELY REGULATE FLOW RATES AND IS PRECISION BUILT WITH EXACTING TOLERANCES AND FINISHES. TO INSURE SATISFACTORY PERFORMANCE, THE REGULATED FLUID **MUST BE CLEAN** AND FREE OF DIRT OR SOLIDS.

THE INSTALLATION OF A FILTER OR STRAINER IS RECOMMENDED, JUST UPSTREAM FROM THE CONTROLLER.

Model	Strainer	Filter
FM38, FM50	-	10 Micron
FM75	200 mesh	75 Micron

EQUALLY IMPORTANT: WHEN DIS-ASSEMBLING, SERVICING, OR CLEANING THE CONTROLLER, THE INTERNAL PARTS MUST BE HANDLED WITH CARE TO PREVENT DAMAGING THE SURFACE FINISH IN ANY WAY.

OPERATION OF A KATES ADJUSTABLE FLOW RATE CONTROLLER THAT IS SUPPLIED BY A POSITIVE DISPLACEMENT PUMP, WILL BE SATISFACTORY ONLY IF A PRESSURE-RELIEVING VALVE IS CONNECTED BETWEEN THE PUMP AND THE CONTROLLER. THIS IS TO BYPASS EXCESS FLUID BACK TO THE FLUID SOURCE, OR TO THE INTAKE OF THE PUMP.

INSTALLATION

1. The Kates flow controller is shipped fully assembled, ready for operation, with all parts in place. It is completely self-contained, requires no outside source of power, no straight piping runs, and is as simple to install as an ordinary ball valve.
2. Upstream and downstream shutoff valves and a bypass valve should be installed (see Fig. 1) so that the controller may be opened for inspection and cleaning without requiring complete system shutdown.
3. Before installing the controller be sure to flush out the piping system to remove any foreign material such as dirt, scale, chips, etc.
4. The controller should be installed at a point in the pipe where **it will be completely filled with liquid under all conditions of operation**. On threaded connections, apply pipe thread compound sparingly to male threads only so that surplus will not get inside the controller and cause "sticking" or prevent operation.

START UP PRODEDURE

1. Place controller "on stream" by opening upstream and downstream shutoff valves and slowly closing the bypass valve around the controller. The controller will now regulate the flow rate at the set value.
2. When normal fluid temperature is above room temperature, especially with viscous fluids, there may be a "warming up" period until the controller reaches the same temperature as the fluid. During this warming up period, the controller may be somewhat sluggish in action. If desired, this warming up period may be eliminated by the use of a heating coil or jacket.

SERVICE INSTRUCTIONS

The Kates Flow Rate Controller has only one moving element, and is designed so that there are no complex linkages, delicate bearings, or any failure-prone components. Therefore, occasional cleaning may be the only servicing the controller will require.

CAUTION: MAKE SURE THAT THE CONTROLLER IS RELIEVED OF PRESSURE BEFORE ATTEMPTING TO SERVICE OR CLEAN.

TO CLEAN CONTROLLER

CAUTION: in all cleaning operations, be very careful not to scratch, nick or mark any surfaces or edges.

1. It is necessary to remove the controller from the line to clean. If installation includes proper shutoff and bypass valves, operate these and take the controller out of line.
2. Arrange a clean area where internal trim parts can be placed and kept free of lint or grit.
3. Unscrew valve tube from the body. (See Fig. 2 for part descriptions.)
4. Pull out the valve tube, valve sleeve and spring and put it in the clean area.
5. Remove the snap ring from the adjuster needle bore. **Notice: Never perform this operation while the controller is pressurized.**
6. Unscrew adjuster needle from the body.
7. Thoroughly clean all the parts which have been removed from the controller by immersing them in a suitable solvent. Thoroughly clean and flush inside of controller body with the solvent, and drain. Because of the closely fitted parts, it is VERY IMPORTANT that all parts and surfaces, including valve ports, be COMPLETELY CLEAN. Any dirt, sediment, coating or gummy residue must be completely removed. Wipe all parts and surfaces dry with a clean, lint-free cloth. CAUTION: in all cleaning operations, be very careful not to scratch, nick or mark any surfaces or edges.

8. The standard o-ring material for the Kates flow controller is PTFE, which has no elastic memory. It may be necessary to install new o-rings whenever the controller is disassembled.
9. Holding the valve sleeve with the open end up, install the spring in the seat at the bottom of the valve sleeve bore.
10. Still holding the valve sleeve with open end up, insert the valve tube in the valve sleeve bore.
11. Once the valve tube and sleeve are put together, turn the assembly so the valve sleeve is on top.
12. Push the valve sleeve down on the valve tube to check if the parts move freely. If the parts do not move freely repeat the cleaning and then continue. If the parts do not move freely after several cleanings, a replacement controller maybe required.
13. Slowly bring the body down over the valve sleeve until the body threads engage with the valve tube threads.
14. Screw the valve tube into the body until the valve tube flange stops against the body.

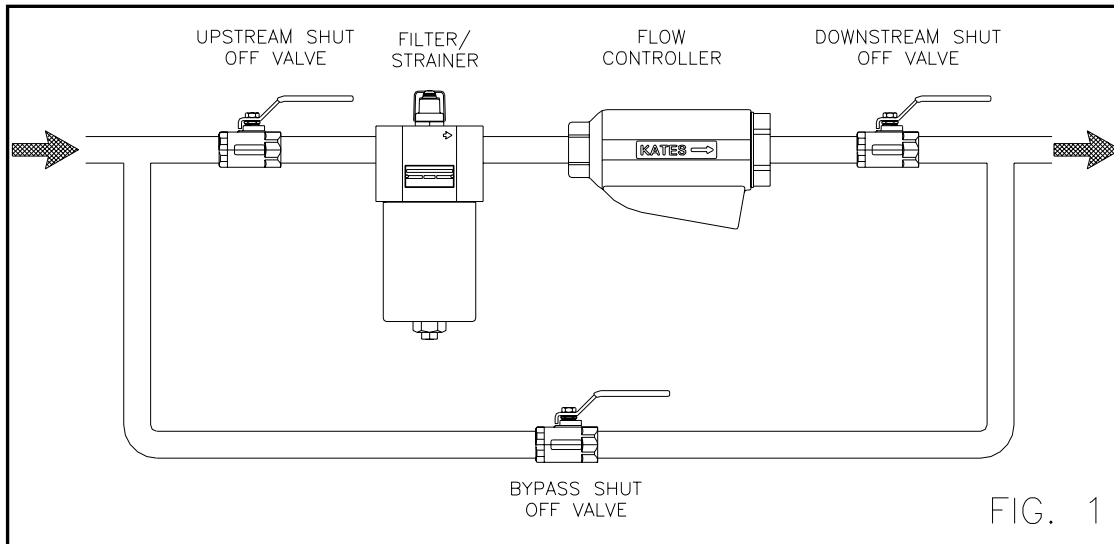

FIG. 1

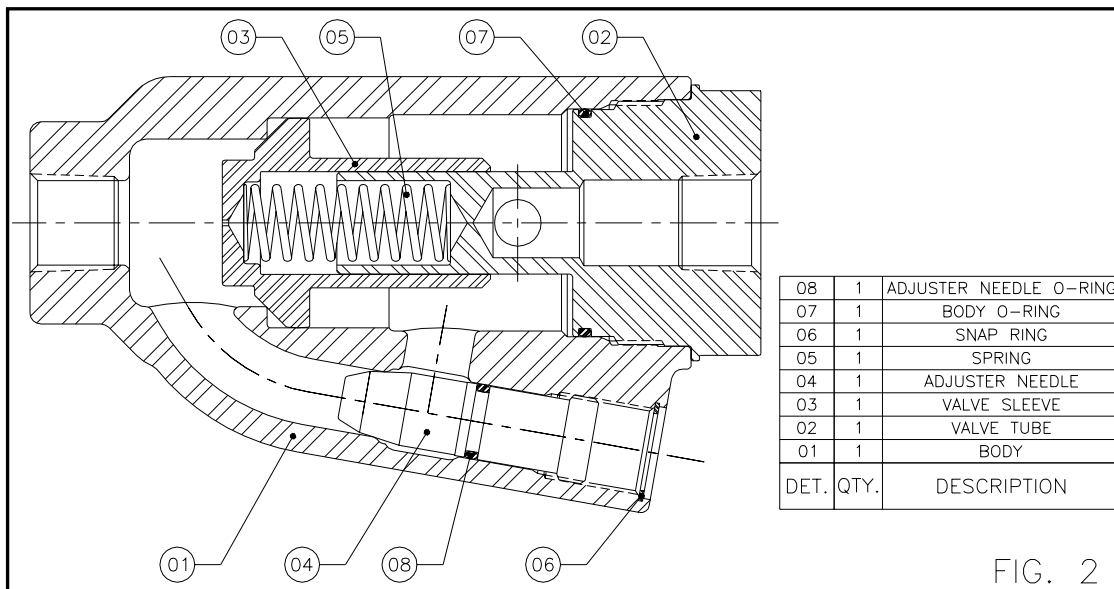

FIG. 2

PRODUCT WARRANTY

The W.A. KATES COMPANY guarantees every piece of equipment manufactured by it to be inspected, tested, and free from defects in workmanship or material when shipped from its factory. No warranty of corrosion resistance of any parts or assembly is expressed or implied.

This guarantee is valid for one year from date of shipment from its plant. Within that time, the W.A. KATES COMPANY will replace free of charge any equipment returned, with shipping charges prepaid, found to have been defective at time of shipment.

This warranty does not apply to : (a) damage resulting from misuse or inadequate handling; (b) damage resulting from continued use after defect is apparent; (c) any other damage, loss or liability; or (d) any piece of equipment that is changed, modified or altered in any way after it leaves the factory.

The liability of the W.A. KATES COMPANY shall be limited to the replacement, f.o.b. our factory, of any equipment found to have been defective at time of shipment with duplicate or similar equipment of equal performance rating, but such liability shall in no event exceed the contract price for said equipment.

W. A. KATES CO. 1363 Anderson, Clawson, Michigan 48017
(248) 435-8225 - Fax (248) 435-8255
E-mail info@wakates.com
WWW <http://www.wakates.com>